

PRODUCT FEATURES

- Wi-Fi/BLE thermostat
- Internal room sensor
- Floor sensor
- Power regulator
- Temperature limiter
- 3 modes: Heat - Cool - Eco
- Hysteresis/PWM
- Temperature calibration
- Open window detection
- External room sensor (wired by cable)
- Google Home, Amazon Alexa and open API (pending)
- Profiles; Home - Away - Night - Holiday
- ZeroX™ detection
- Relay status icon
- Adjustable display brightness
- Single pole switch
- Lock mode/child lock
- Weekly schedule in app
- Active power metering
- Firmware update (OTA)

PRODUCT DATA

Material	Polycarbonate (PC)
Mounting	European Junction Box
Colour	White RAL 9010
Min. and max ambient humidity (RH%)	10 to 85%
Ambient temperature range in use	5 to 40°C
Ambient temperature range in storage	-30 to 70°C
Min/max installation temperature	5 to 40°C

THERMOSTAT DATA

Compatible NTC-sensors (kΩ @ 25°C)	6.8, 10, 12, 15, 22, 33, 47, 100
Power regulator	Timed cycle 0-30 minutes
Error margin temperature	0,5
Temperature sensitivity	±0,5
Hysteresis	0,3 to 3,0 (default hysteresis 0,5)
Ohm value at 25°C	10kΩ
Max length of NTC sensor	50m
Regulation temperature	5 to 40°C

STANDARDS

Certification	RoHS, Reach
EN Standards	CE, Nemko
IP Code	IP21

WARRANTY

Warranty international	2 years
------------------------	---------

HEATIT WIFI6 THERMOSTAT WHITE RAL 9010

Wi-Fi Thermostat 3600W 16A

Art.no	5430541
GTIN	7071236018100

Heatit WiFi6 is an electronic thermostat designed for electrical heating and water based heating control. The thermostat can be controlled using the "MyHeatit" App via Wi-Fi, or via the buttons on the front of the thermostat. You can also use Bluetooth (BLE) during the setup of the thermostat. The thermostat has a user friendly interface.

Heatit WiFi6 has 3 modes: Heat - Cool and Eco.

The thermostat fits in standard European junction boxes and may be used with most System 55 frames. It has a sturdy metal frame for secure fastening in the junction box. The thermostat has a built-in room temperature sensor. Two additional external temperature sensors may also be connected. The device has an open API and supports Amazon Alexa and Google Home (open API, Amazon Alexa and Google Home is pending).

The installer configures the system via Wi-Fi. If Wi-Fi is not available, the system can be configured via Bluetooth. After the system is set up, the installer can add the property to the customer. The customer can then add the system to their local Wi-Fi network.

All our new Heatit products with Wi-Fi support will be supported through our app; "MyHeatit". In the "MyHeatit" App, you can create your own profiles such as "Home - Away - Night - Holiday" and thus control, monitor and organize all the connected devices, or control them via weekly schedule.

The thermostat can communicate over a local API, where the user can make integration with a local gateway, server or controller that offers such a service.

Heatit WiFi6 has active power metering, and it gives you the real time information about the power consumption. It also allows you to set the power metering value manually in case of connection with a contactor.

The device has implemented ZeroX™ technology. This technology makes sure the relay switches at 0V when turning on and off. With this technology the thermostat will have a much longer lifetime.

IOT / SMART HOME SPECIFIC DATA

Alternate IoT-communication protocols	WiFi (802.11 b/g/n) 2,4GHz Bluetooth® low energy
Min radio frequency range	30m
Over The Air update (OTA)	Yes
Push buttons	3
Temperature measurement range	5 to 40°C
Primary IoT Protocol	WiFi Bluetooth

ELECTRO TECHNICAL DATA

Voltage	230VAC 50Hz
Max load (resistive load)	3600W
Own power usage	2W
Switch type	One-pole switch
Max load (resistive load)	16A
Method of regulation	Button regulation Regulation via App
Connection type	Screw clamps
Connection terminals diameter	0.2 to 2.5mm ²
Max tightening torque connections	2N-m
Voltage Output	230VAC 50Hz
Grounding	No



PRODUCT DIMENSIONS

Product height/diameter	84mm	Product Width	84mm
Product length	45.5mm	Product net weight	136g

MAINTENANCE

The device is maintenance-free. Indoor use only.

ADDITIONAL INFORMATION

Approved for use in bathrooms.

ZeroX™ Detection is pronounced Zero Cross Detection.

PRODUCT INFO RETURN AND RECYCLING

The product must be recycled as electronic waste.

DISCLAIMER

The device can withstand a load of max 16A/3600W at 230VAC. We recommend a contactor for loads above 13A.

Never change the front from one thermostat to another.

General info;

Worth noting regarding correct installation of thermostats.

When two or more thermostats are mounted too close to each other, the heat they emit, can interfere with the temperature sensors and the temperature in the junction box becomes too high. This can cause inaccurate temperature readings, especially under high load, leading to incorrect heating control. To avoid such issues, thermostats should be installed as far apart as possible and always in separate junction boxes. This ensures more accurate temperature readings.

In multi-frames with multiple units, the thermostat should always be mounted at the bottom, and no more than one thermostat should ever be installed in a multi-frame.

We develop and design our products according in accordance with our strict quality requirements (ISO 9001) and environmental requirements (ISO 14001).

All electrical installations must be carried out by an authorized electrical installer. The product must be installed in accordance with our installers manual and national building codes. Any wrongful installation, misuse, damage of the product, is not covered under warranty.

Updated documentation is available at www.heatit.com and/or documents.heatit.com

Heatit Controls AB can not be held liable for any type of errors or omissions in our product information.

Product specifications may change without further notice.

HEATIT WiFi6 THERMOSTAT

DIMENSIONS

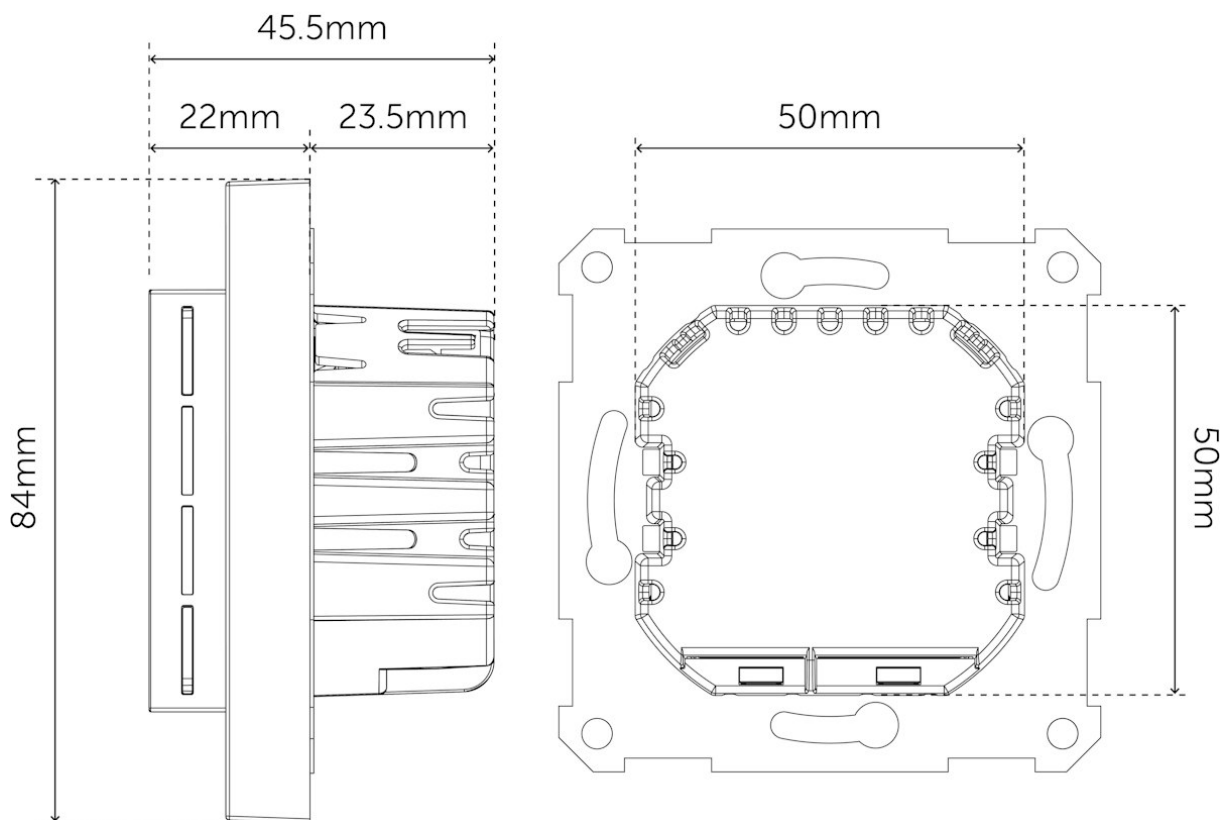

Heatit WiFi6 Thermostat White RAL 9010 can be ordered from
www.heatit.com/5430541

All additional documentation are available on the above adress and on documents.heatit.com/5430541

